

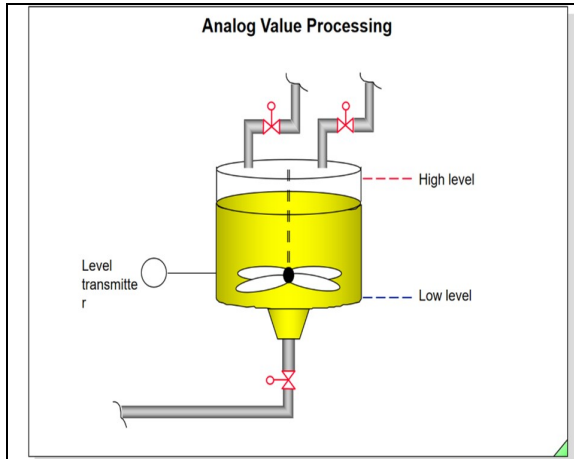

## طراحی چند تمرین PLC

### تمرین ۱:



مخزن استونه ای با مقطع دایره ای به شعاع یک متر و ارتفاع مخزن 2.5 متر می باشد.

در نرم افزار Micro/Win برنامه کنترلی بنویسید که :

الف) از یک سنسور سطح سنج مجهز به یک مبدل 4-20 mA مقدار مایع داخل مخزن را اندازه گیری نموده و آنرا برحسب لیتر در یک محل حافظه مشخصی ذخیره نماید.

ب) در داخل مخزن دو سنسور سطح سنج یکی به عنوان LL-Sensor و دیگری به عنوان HL-Sensor در بالای مخزن قرار دارد برنامه کنترلی طوری طراحی نمایید که وقتی محلول داخل مخزن به سطح LL می رسد هر دو ورودی بالایی باز شوند و وقتی مقدار مایع داخل مخزن به نصف می رسد (یا توسط یک سنسور دیجیتال که در وسط منبع قرار داده می شود آشکار سازی انجام می شود یا با استفاده از سنسور آنالوگ آشکار سازی می شود) یکی از شیرهای ورودی بسته شود و وقتی سطح مایع به سنسور HL می رسد شیر دوم هم بسته شود.

ج) این عمل بین دو سطح LL و HL به طور خود کار تکرار شود.

When the value measured at an analog channel of the module exceeds the overflow range, OB82 is called, as well as when it re-enters the range.

د)

حل: برای حل در ابتدا بایستی خواسته های کنترلی را خوب متوجه بشویم . که در صورت این تمرینات تشریح شده است.

در مرحله بعد نقشه های قدرت و کنترلی را توسط یک نرم افزار نقشه کشی مانند اتوکد رسم نماییم و در آن تمامی سنسورها و محرکها را مشخص نموده و مهمتر از همه اینها جدول آدرسهای ورودی و خروجی را مشخص نماییم.

شرح سنسور یا محرک	آدرس ورودی و خروجی	توضیحات
سنسور آنالوگ سطح سنج	AI1 OR AIW0 OR PIW 200	سنسور و ترانسدیوسر از نوع جریانی با خروجی 4-20mA
سنسور LL	I 0.0	این سنسور در ارتفاع ۲۰ سانتی متری از کف مخزن قرار دارد
سنسور HL	I 0.1	این سنسور در ارتفاع ۱۰ سانتی متری از سقف مخزن قرار دارد
سنسور وسط ML	I 0.2	این سنسور در وسط مخزن قرار داده می شود تا وقتیکه سطح مایع به این نقطه رسید فقط یک شیر ورودی باز شود
شیر شماره ۱ خروجی	Q 0.0	
شیر شماره ۲ ورودی	Q0,2- Q 0.1	
آدرس اعلام خطا وقتی سیگنال ورودی سنسور در حالت Overrange است	Q 0.3	این قسمت وقتیکه در S7-300 و یا S7-400 برنامه نویسی می کنیم انجام می دهیم

در این مرحله بایستی انتخاب PLC مناسب به لحاظ سخت افزاری و نرم افزاری انجام شود. در خصوص سیستمهای اتوماسیون زمینس:

سخت افزار LOGO	نرم افزار LogoComfort V5
سخت افزار S7-200	نرم افزار Micro/Winn
سخت افزار S7-300 یا S7-400	نرم افزار Simatic Manager

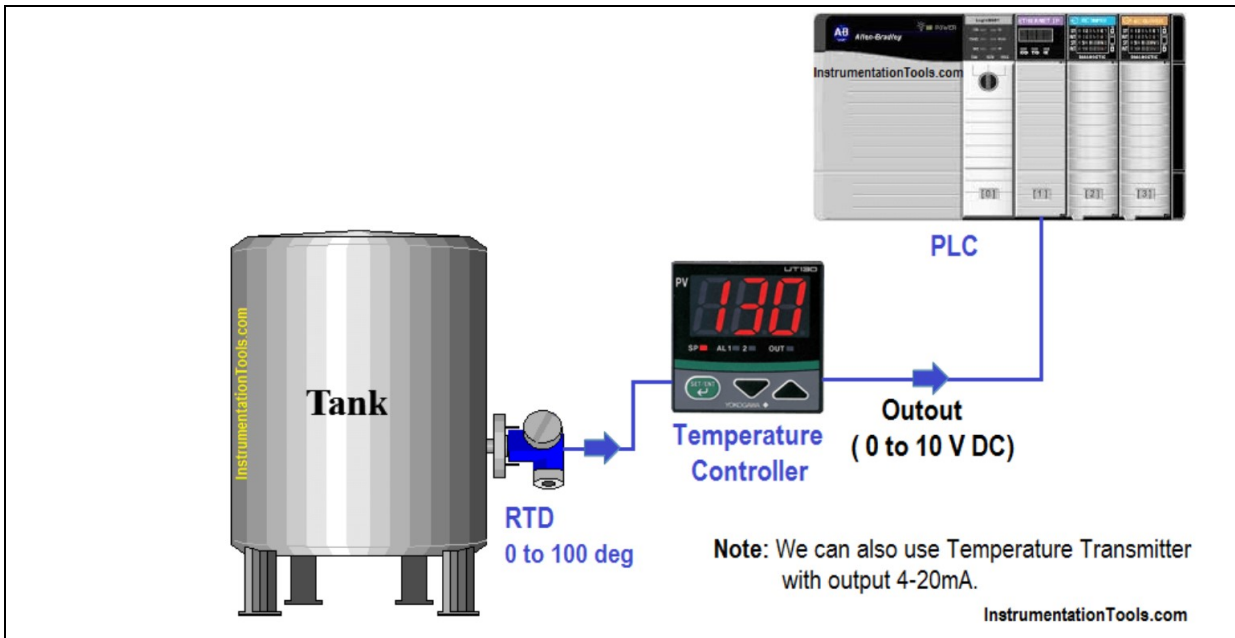
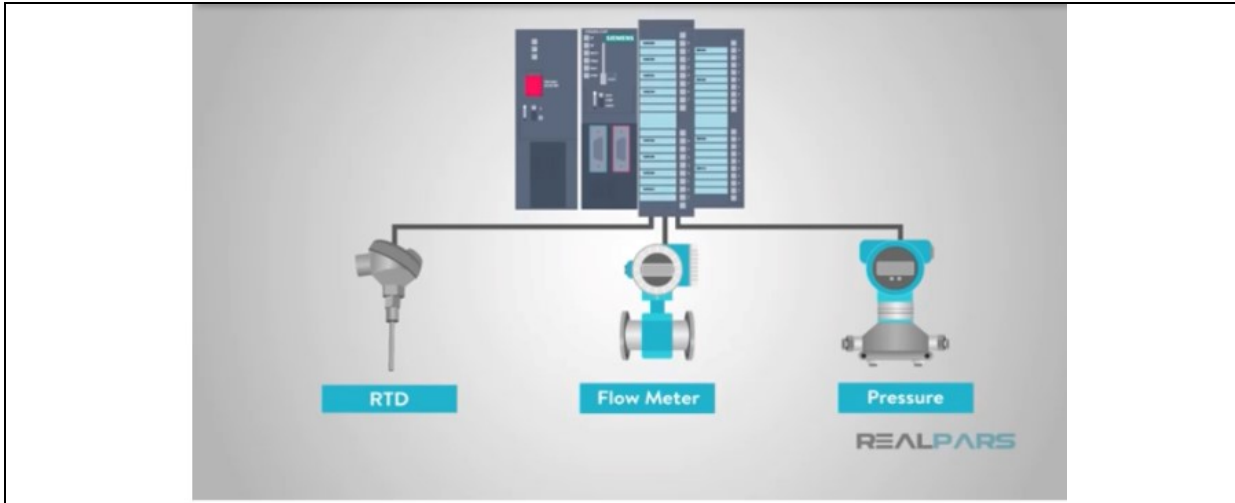

**Interface Unit**

- By adding various interface units, connection to the main network is available. \*CC-Link, MODBUS, PROFIBUS-DP
- It is possible to circuit breaker ON/OFF management by remote control and monitoring of various information.

**- Network Instance**

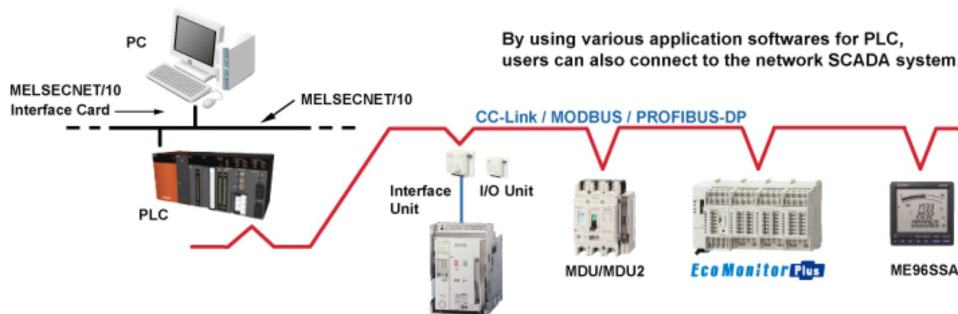

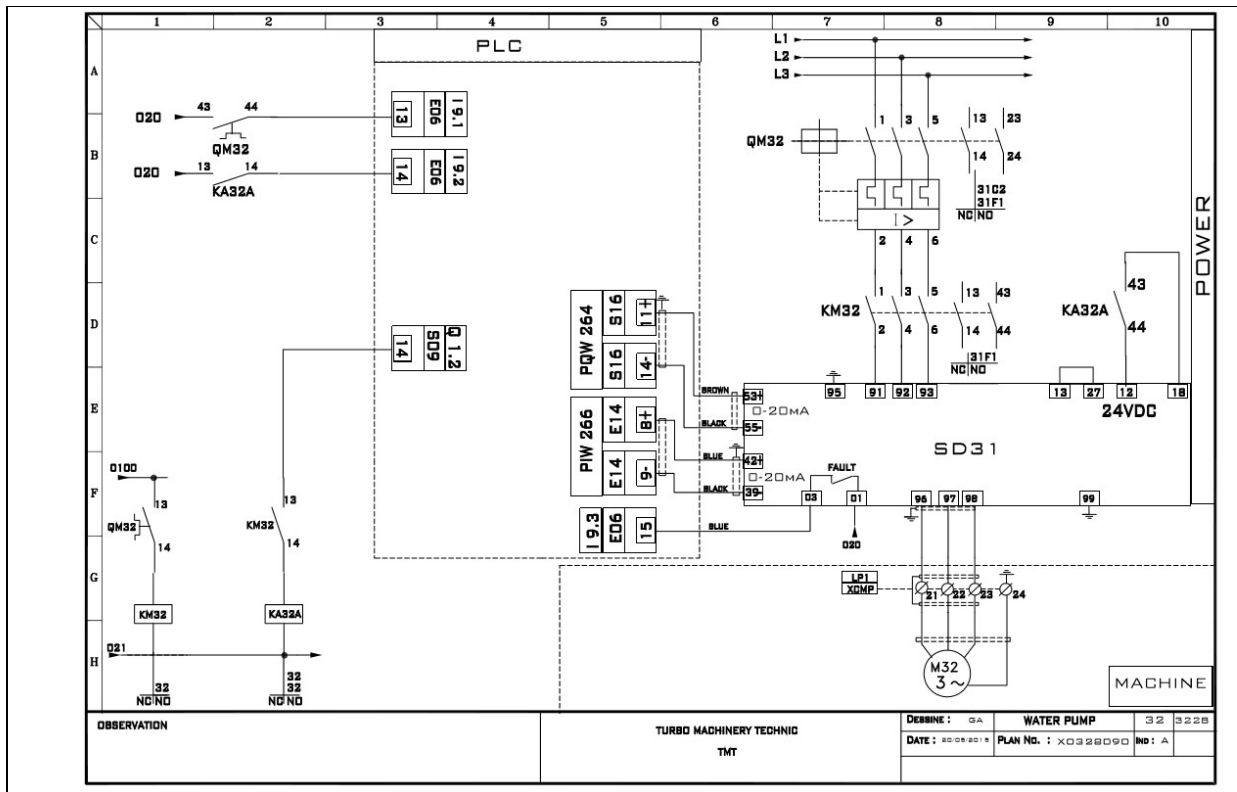
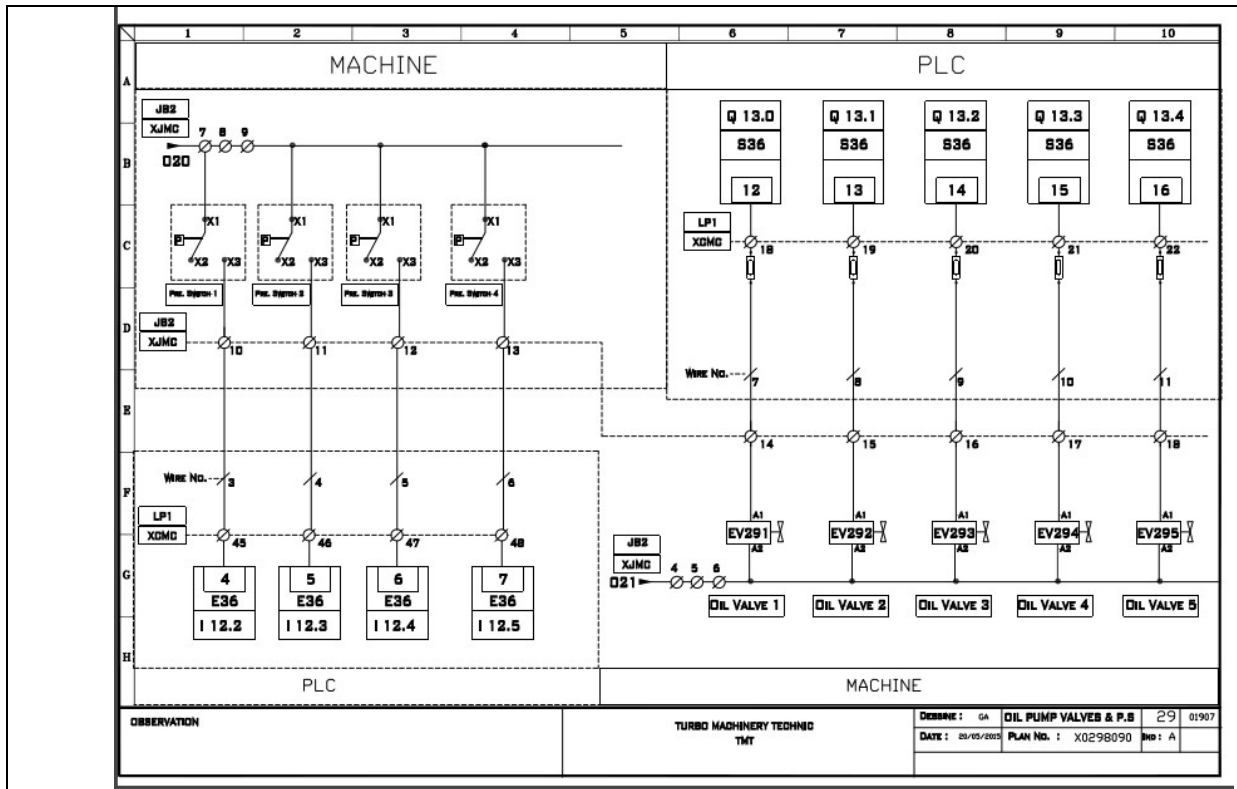

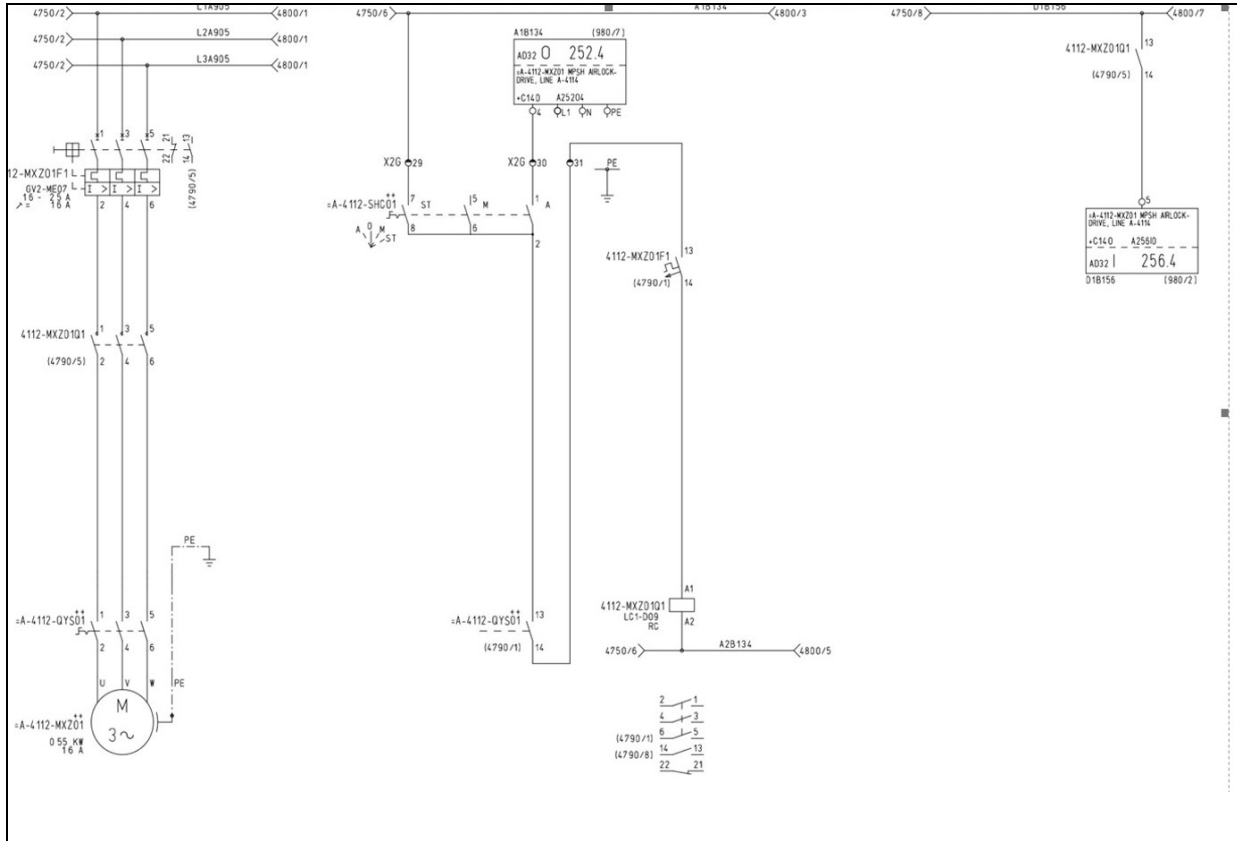

تمرین ۲:

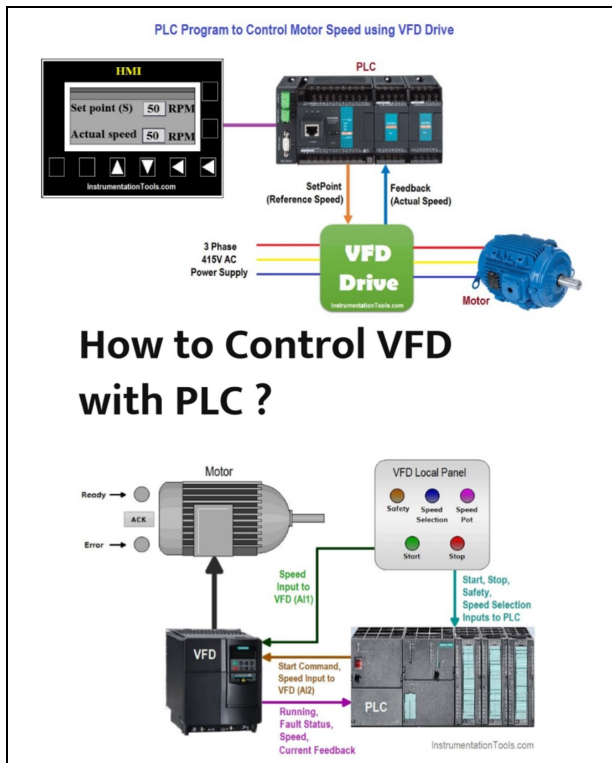

How to Control VFD with PLC ?

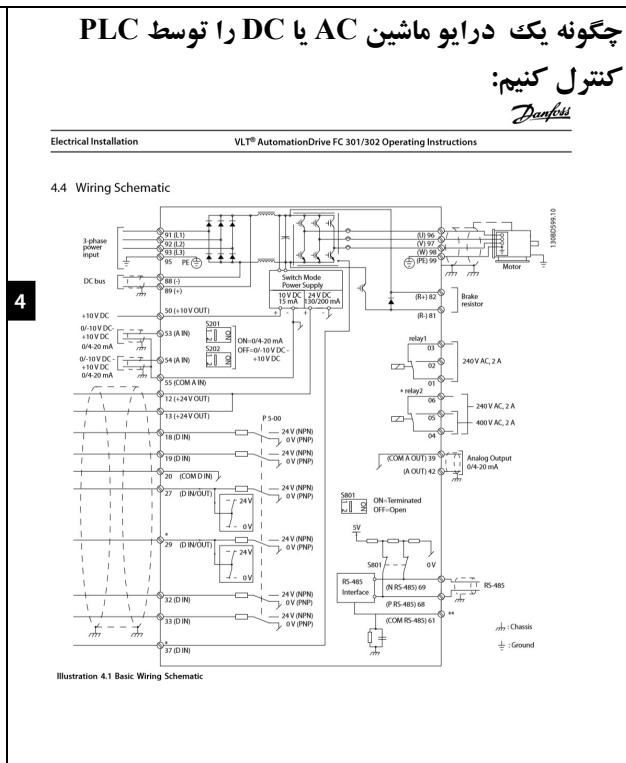



### حل:

توضیحات	آدرس خروجی	آدرس ورودی	شرح ورودی
نامی استارت	Q 1.0	I 1.0 or M1.0	Start Drive
نامی استپ		I 1.1 or M 1.1	Stop Drive
ورودی از خروجی درایو به PLC		I 1.2	Drive Fault
ورودی از کلید اتوماتیک محافظ موتور		I 1.3	Motor Protection Circuit Breaker
آدرس خروجی سیگنال آنالوگی: 4-20mA Or 0-10 V	AQW10 or PQW 100		Analog Output from PLC For Speed Control
آدرس ورودی به PLC برای چک کردن سرعت درایو		AIW10 OR PIW 100	Analog Input from Drive For Speed Control

## شناخت کامل تجهیزات سخت افزاری و نرم افزاری PLC های مختلف

Table G-3 Summary of S7-200 CPU Memory Ranges and Features

Description	CPU 221	CPU 222	CPU 224	CPU 226	CPU 226XM
User program size	4096 bytes	4096 bytes	8192 bytes	8192 bytes	16384 bytes
User data size	2048 bytes	2048 bytes	5120 bytes	5120 bytes	10240 bytes
Process-image input register	I0.0 to I15.7	I0.0 to I15.7	I0.0 to I15.7	I0.0 to I15.7	I0.0 to I15.7
Process-image output register	Q0.0 to Q15.7	Q0.0 to Q15.7	Q0.0 to Q15.7	Q0.0 to Q15.7	Q0.0 to Q15.7
Analog inputs (read only)	--	AIW0 to AIW30	AIW0 to AIW62	AIW0 to AIW62	AIW0 to AIW62
Analog outputs (write only)	--	AQW0 to AQW30	AQW0 to AQW62	AQW0 to AQW62	AQW0 to AQW62
Variable memory (V)	VB0 to VB2047	VB0 to VB2047	VB0 to VB5119	VB0 to VB5119	VB0 to VB10239
Local memory (L) <sup>1</sup>	LB0 to LB63	LB0 to LB63	LB0 to LB63	LB0 to LB63	LB0 to LB63
Bit memory (M)	M0.0 to M31.7	M0.0 to M31.7	M0.0 to M31.7	M0.0 to M31.7	M0.0 to M31.7
Special Memory (SM) Read only	SM0.0 to SM179.7 SM0.0 to SM29.7	SM0.0 to SM299.7 SM0.0 to SM29.7	SM0.0 to SM549.7 SM0.0 to SM29.7	SM0.0 to SM549.7 SM0.0 to SM29.7	SM0.0 to SM549.7 SM0.0 to SM29.7
Timers	256 (T0 to T255)	256 (T0 to T255)	256 (T0 to T255)	256 (T0 to T255)	256 (T0 to T255)
Retentive on-delay	1 ms: T0, T64 10 ms: T1 to T4, and T65 to T68 100 ms: T5 to T31, and T69 to T95	T0, T64 T1 to T4, and T65 to T68 T5 to T31, and T69 to T95	T0, T64 T1 to T4, and T65 to T68 T5 to T31, and T69 to T95	T0, T64 T1 to T4, and T65 to T68 T5 to T31, and T69 to T95	T0, T64 T1 to T4, and T65 to T68 T5 to T31, and T69 to T95
On/Off delay	1 ms: T32, T96 10 ms: T33 to T36, and T97 to T100 100 ms: T37 to T63, and T101 to T255	T32, T96 T33 to T36, and T97 to T100 T37 to T63, and T101 to T255	T32, T96 T33 to T36, and T97 to T100 T37 to T63, and T101 to T255	T32, T96 T33 to T36, and T97 to T100 T37 to T63, and T101 to T255	T32, T96 T33 to T36, and T97 to T100 T37 to T63, and T101 to T255
Counters	C0 to C255	C0 to C255	C0 to C255	C0 to C255	C0 to C255
High-speed counter	HC0, HC3, HC4, and HC5	HC0, HC3, HC4, and HC5	HC0 to HC5	HC0 to HC5	HC0 to HC5
Sequential control relays (S)	S0.0 to S31.7	S0.0 to S31.7	S0.0 to S31.7	S0.0 to S31.7	S0.0 to S31.7
Accumulator registers	AC0 to AC3	AC0 to AC3	AC0 to AC3	AC0 to AC3	AC0 to AC3
Jumps/Labels	0 to 255	0 to 255	0 to 255	0 to 255	0 to 255
Call/Subroutine	0 to 63	0 to 63	0 to 63	0 to 63	0 to 127
Interrupt routines	0 to 127	0 to 127	0 to 127	0 to 127	0 to 127
Positive/negative transitions	256	256	256	256	256
PID loops	0 to 7	0 to 7	0 to 7	0 to 7	0 to 7
Ports	Port 0	Port 0	Port 0	Port 0, Port 1	Port 0, Port 1

<sup>1</sup> LB60 to LB63 are reserved by STEP 7-Micro/WIN, version 3.0 or later.



### Accessing Data in the Memory Areas

**Process-Image Input Register: I**  
 The S7-200 samples the physical input points at the beginning of each scan cycle and writes these values to the process-image input register. You can access the process-image input register in bits, bytes, words, or double words:

Bit: I[byte address].[bit address] I0.1  
 Byte, Word, or Double Word: I[size][starting byte address] IB4

**Process-Image Output Register: Q**  
 At the end of the scan cycle, the S7-200 copies the values stored in the process-image output register to the physical output points. You can access the process-image output register in bits, bytes, words, or double words:

Bit: Q[byte address].[bit address] Q1.1  
 Byte, Word, or Double Word: Q[size][starting byte address] QB5

**Variable Memory Area: V**  
 You can use V memory to store intermediate results of operations being performed by the control logic in your program. You can also use V memory to store other data pertaining to your process or task. You can access the V memory area in bits, bytes, words, or double words:

Bit: V[byte address].[bit address] V10.2  
 Byte, Word, or Double Word: V[size][starting byte address] VW100

**Bit Memory Area: M**  
 You can use the bit memory area (M memory) as control relays to store the intermediate status of an operation or other control information. You can access the bit memory area in bits, bytes, words, or double words:

Bit: M[byte address].[bit address] M26.7  
 Byte, Word, or Double Word: M[size][starting byte address] MD20

Table 1-1 Comparison of the S7-200 CPU Models

Feature	CPU 221	CPU 222	CPU 224	CPU 226	CPU 226XM
Physical size (mm)	90 x 80 x 62	90 x 80 x 62	120.5 x 80 x 62	190 x 80 x 62	190 x 80 x 62
Program memory	4096 bytes	4096 bytes	8192 bytes	8192 bytes	16384 bytes
Data memory	2048 bytes	2048 bytes	5120 bytes	5120 bytes	10240 bytes
Memory backup	50 hours typical	50 hours typical	190 hours typical	190 hours typical	190 hours typical
Local on-board I/O	6 In/4 Out	8 In/6 Out	14 In/10 Out	24 In/16 Out	24 In/16 Out
Expansion modules	0 modules <sup>1</sup>	2 modules <sup>1</sup>	7 modules <sup>1</sup>	7 modules <sup>1</sup>	7 modules <sup>1</sup>
High-speed counters					
Single phase	4 at 30 kHz	4 at 30 kHz	6 at 30 kHz	6 at 30 kHz	6 at 30 kHz
Two phase	2 at 20 kHz	2 at 20 kHz	4 at 20 kHz	4 at 20 kHz	4 at 20 kHz
Pulse outputs (DC)	2 at 20 kHz	2 at 20 kHz	2 at 20 kHz	2 at 20 kHz	2 at 20 kHz
Analog adjustments	1	1	2	2	2
Real-time clock	Cartridge	Cartridge	Built-in	Built-in	Built-in
Communications ports	1 RS-485	1 RS-485	1 RS-485	2 RS-485	2 RS-485
Floating-point math	Yes				
Digital I/O image size	256 (128 in, 128 out)				
Boolean execution speed	0.37 microseconds/instruction				

<sup>1</sup> You must calculate your power budget to determine how much power (or current) the S7-200 CPU can provide for your configuration. If the CPU power budget is exceeded, you may not be able to connect the maximum number of modules. See Appendix A for CPU and expansion module power requirements, and Appendix B to calculate your power budget.

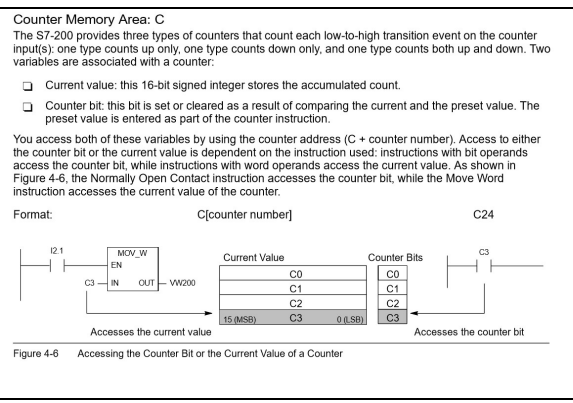
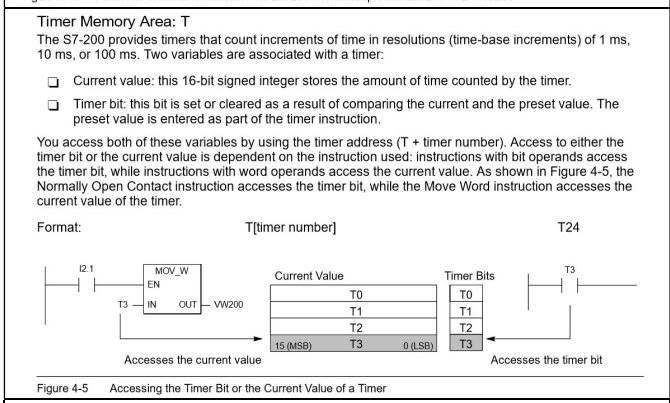
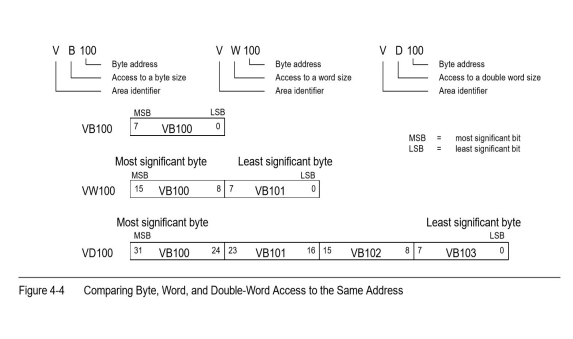
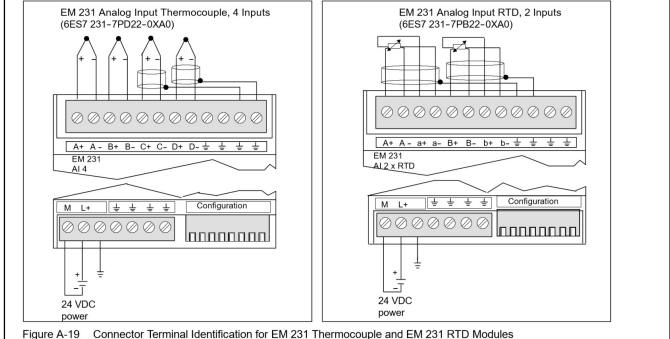

**Special Memory: SM**  
 The SM bits provide a means for communicating information between the CPU and your program. You can use these bits to select and control some of the special functions of the S7-200 CPU, such as: a bit that turns on for the first scan cycle, a bit that toggles at a fixed rate, or a bit that shows the status of math or operational instructions. (For more information about the SM bits, see Appendix D.) You can access the SM bits as bits, bytes, words, or double words:

Bit: SM[byte address].[bit address] SM0.1  
 Byte, Word, or Double Word: SM[size][starting byte address] SMB86



**Analog Inputs: AI**

The S7-200 converts an analog value (such as temperature or voltage) into a word-length (16-bit) digital value. You access these values by the area identifier (AI), size of the data (W), and the starting byte address. Since analog inputs are words and always start on even-number bytes (such as 0, 2, or 4), you access them with even-number byte addresses (such as AIW0, AIW2, or AIW4). Analog input values are read-only values.

Format: AIW[starting byte address] AIW4

**Analog Outputs: AQ**

The S7-200 converts a word-length (16-bit) digital value into a current or voltage, proportional to the digital value (such as for a current or voltage). You write these values by the area identifier (AQ), size of the data (W), and the starting byte address. Since analog outputs are words and always start on even-number bytes (such as 0, 2, or 4), you write them with even-number byte addresses (such as AQW0, AQW2, or AQW4). Analog output values are write-only values.

Format: AQW[starting byte address] AQW4

**Sequence Control Relay (SCR) Memory Area: S**

SCRs or S bits are used to organize machine operations or steps into equivalent program segments. SCRs allow logical segmentation of the control program. You can access the S bits as bits, bytes, words, or double words.

Bit: S[byte address].[bit address] S3.1  
 Byte, Word, or Double Word: S[size][starting byte address] SB4

**Format for Real Numbers**

Real (or floating-point) numbers are represented as 32-bit, single-precision numbers, whose format is described in the ANSI/IEEE 754-1985 standard. See Figure 4-8. Real numbers are accessed in double-word lengths.

For the S7-200, floating point numbers are accurate up to 6 decimal places. Therefore, you can specify a maximum of 6 decimal places when entering a floating-point constant.



Figure 4-8 Format of a Real Number

**Local Memory Area: L**

The S7-200 provides 64 bytes of local memory of which 60 can be used as scratchpad memory or for passing formal parameters to subroutines.

**Tip**

If you are programming in either LAD or FBD, STEP 7-Micro/WIN reserves the last four bytes of local memory for its own use. If you program in STL, all 64 bytes of L memory are accessible, but it is recommended that you do not use the last four bytes of L memory.

Local memory is similar to V memory with one major exception. V memory has a global scope while L memory has a local scope. The term global scope means that the same memory location can be accessed from any program entity (main program, subroutines, or interrupt routines). The term local scope means that the memory allocation is associated with a particular program entity. The S7-200 allocates 64 bytes of L memory for the main program, 64 bytes for each subroutine nesting level, and 64 bytes for interrupt routines.

The allocation of L memory for the main program cannot be accessed from subroutines or from interrupt routines. A subroutine cannot access the L memory allocation of the main program, an interrupt routine, or another subroutine. Likewise, an interrupt routine cannot access the L memory allocation of the main program or of a subroutine.

The allocation of L memory is made by the S7-200 on an as-needed basis. This means that while the main portion of the program is being executed, the L memory allocations for subroutines and interrupt routines do not exist. At the time that an interrupt occurs or a subroutine is called, local memory is allocated as required. The new allocation of L memory might reuse the same L memory locations of a different subroutine or interrupt routine.

The L memory is not initialized by the S7-200 at the time of allocation and might contain any value. When you pass formal parameters in a subroutine call, the values of the parameters being passed are placed by the S7-200 in the appropriate L memory locations of the called subroutine. L memory locations, which do not receive a value as a result of the formal parameter passing step, will not be initialized and might contain any value at the time of allocation.

Bit: L[byte address].[bit address] L0.0  
 Byte, Word, or Double Word: L[size][starting byte address] LB33

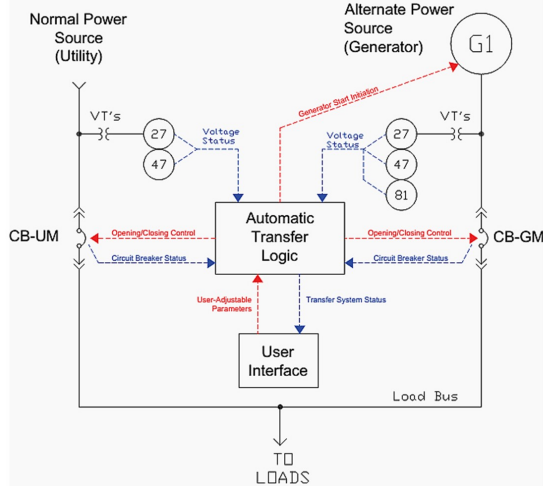

**تمرین ۳: طراحی یک سیستم کنترل اتوماتیک چنج - اور برقی شهر و ژنراتور اضطراری توسط PLC**

مراحل حل:



- ۱- شناخت دقیق اجزای تشکیل دهنده این سیستم
- ۲- شناخت دقیق رله های حفاظتی و کنترلی
- ۳- شناخت دقیق مکانیزم های شارژ و قطع و وصل کلیدهای اتوماتیک

**بعد از شناخت کامل فرایند جدول ورودیها و خروجیها را مشخص می کنیم**

شرح ورودی	آدرس ورودی	آدرس خروجی	توضیحات
Under/Over Generator Voltage	I 3.2		ورودی دیجیتال از رله ولتاژ کم و زیاد از شبکه برقی ژنراتور
Phase Sequence Input Digital Address Of City Net	I 3.3		رله توالی فاز برقی شهر
Phase Sequence Digital Address Of Gen. Net	I 3.4		رله توالی فاز برقی ژنراتور
Gen. Under Frequency Relay Input Address	I 3.5		آدرس ورودی دیجیتال رله فرکانس کم ژنراتور
Utility C.B. Fault Input Digital Add.	I 3.6		آدرس ورودی دیجیتال از کنتاکت حالت تریب کلید برقی شهر
Gen. C.B. Fault Input Digital Add.	I 3.7		آدرس ورودی دیجیتال از کنتاکت حالت تریب کلید ژنراتور
Output Command For Opening U.C.B	-	Q 2.0	فرمان خروجی برای قطع کلید برقی شهر
Output Command For Opening G.C.B	-	Q 2.1	فرمان خروجی برای قطع کلید برقی ژنراتور
Output Command For Closing U.C.B	-	Q 2.2	فرمان خروجی برای وصل کلید برقی شهر
Output Command For Closing G.C.B	-	Q 2.2	فرمان خروجی برای وصل کلید برقی ژنراتور
CONTROL SIGNAL FOR STARTING DIESEL GENERATOR	-	Q 2.3	فرمان به طرف ژنراتور برای استارت دیزل ژنراتور

شرح ورودی	آدرس ورودی	آدرس خروجی	توضیحات
Hand/Auto CB O/C	I 2.0 or M2.0	-	کلید H-0-A برای مشخص کردن وضعیت اتوماتیک و دستی
START/STOP UTILITY C.B	I 2.1, I 2.2 OR M 2.1 OR M2.2		نامی استپ و استارت کلید اتوماتیک برقی شهر
START/STOP GENERATOR C.B	I 2.3, I 2.4 OR M 2.1 OR M2.2		نامی استپ و استارت کلید اتوماتیک برقی ژنراتور
CB1 MOTOR CHARGING COMPLETION	I 2.5		اطمینان از شارژ کامل کلید اتوماتیک برقی شهر
CB2 MOTOR CHARGING COMPLETION	I 2.6		اطمینان از شارژ کامل کلید اتوماتیک برقی ژنراتور
N.O CONTACT OF CITY C.B.	I 2.7		کنتاکت معمولی کلید اتوماتیک برقی شهر
N.O CONTACT OF GENERATOR C.B.	I 3.0		کنتاکت معمولی کلید اتوماتیک برقی ژنراتور
Under/Over Voltage U Net	I 3.1		ورودی دیجیتال از رله ولتاژ کم و زیاد از شبکه برقی شهر

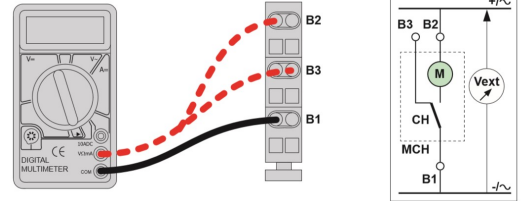

<p style="text-align: center;"><b>Air Circuit Breaker External Labels</b></p> 	 <p style="text-align: center;">CH: spring charged limit switch</p>																																																																		
<ol style="list-style-type: none"> <li>1. OFF button (O)</li> <li>2. ON button (I)</li> <li>3. Main contact position indicator</li> <li>4. Energy storage mechanism status indicator</li> <li>5. Reset Button</li> <li>6. LED Indicators</li> <li>7. Controller</li> <li>8. "Connection", "Test" and "isolated" position stopper (the three-position latching/locking mechanism)</li> <li>9. User-supplied padlock</li> <li>10. Connection "I", "Test" and "isolated" separation "of the position indication</li> <li>11. Connection (CE) Separation, (CD) Test (CT) Position indication contacts</li> <li>12. Rated Name Plate</li> <li>13. Digital Displays</li> <li>14. Mechanical energy storage handle</li> <li>15. Shake (IN/OUT)</li> <li>16. Rocker repository</li> <li>17. Fault trip reset button</li> </ol>																																																																			
<p style="text-align: center;">Indication contacts and remote operation</p> <table border="1"> <thead> <tr> <th colspan="3">Indication contacts</th> </tr> </thead> <tbody> <tr> <td colspan="3"><b>ON/OFF indication contacts (OF)</b></td> </tr> <tr> <td>Changeover contacts (6 A - 240 V)</td> <td></td> <td>4 (standard)</td> </tr> <tr> <td>1 low-level OF to replace 1 standard OF (4 max.)</td> <td></td> <td>LV847339</td> </tr> <tr> <td colspan="3"><b>"Fault trip" indication contacts (SDE)</b></td> </tr> <tr> <td>Changeover contact (6 A - 240 V)</td> <td></td> <td>1 (standard)</td> </tr> <tr> <td>1 additional SDE (6 A - 240 V)</td> <td></td> <td>LV847340</td> </tr> <tr> <td>1 additional low-level SDE</td> <td></td> <td>LV847341</td> </tr> <tr> <td colspan="3"><b>Programmable contacts (programmed via MicroLogic X control unit)</b></td> </tr> <tr> <td>2 contacts (MC) (5 A - 240 V)</td> <td></td> <td>LV847403</td> </tr> <tr> <td colspan="3"><b>Remote operation</b></td> </tr> <tr> <td colspan="3"><b>"Ready to close" contact (1 max.)</b></td> </tr> <tr> <td>1 changeover contact (5 A - 240 V)</td> <td>RF</td> <td>LV847342</td> </tr> <tr> <td>1 low-level changeover contact</td> <td></td> <td>LV847343</td> </tr> <tr> <td colspan="3"><b>Electrical closing pushbutton</b></td> </tr> <tr> <td>1 pushbutton</td> <td>DPTE</td> <td>LV847512</td> </tr> <tr> <td colspan="3"><b>Remote reset after fault trip</b></td> </tr> <tr> <td>Electrical reset</td> <td>RCS</td> <td></td> </tr> <tr> <td>180/130 V AC</td> <td></td> <td>LV847344</td> </tr> <tr> <td>200/240 V AC</td> <td></td> <td>LV847345</td> </tr> <tr> <td>Automatic reset</td> <td>RAAR</td> <td></td> </tr> <tr> <td>Adaptation</td> <td></td> <td>LV847346</td> </tr> </tbody> </table>	Indication contacts			<b>ON/OFF indication contacts (OF)</b>			Changeover contacts (6 A - 240 V)		4 (standard)	1 low-level OF to replace 1 standard OF (4 max.)		LV847339	<b>"Fault trip" indication contacts (SDE)</b>			Changeover contact (6 A - 240 V)		1 (standard)	1 additional SDE (6 A - 240 V)		LV847340	1 additional low-level SDE		LV847341	<b>Programmable contacts (programmed via MicroLogic X control unit)</b>			2 contacts (MC) (5 A - 240 V)		LV847403	<b>Remote operation</b>			<b>"Ready to close" contact (1 max.)</b>			1 changeover contact (5 A - 240 V)	RF	LV847342	1 low-level changeover contact		LV847343	<b>Electrical closing pushbutton</b>			1 pushbutton	DPTE	LV847512	<b>Remote reset after fault trip</b>			Electrical reset	RCS		180/130 V AC		LV847344	200/240 V AC		LV847345	Automatic reset	RAAR		Adaptation		LV847346	<p><b>en</b> The MCH gear motor charges the closing springs automatically after the device closes.</p> <ol style="list-style-type: none"> <li>1. Verify the continuity between terminals B1 and B2.</li> <li>2. Charge the closing spring manually.</li> <li>3. Verify the continuity between terminals B1 and B3.</li> <li>4. Connect the MCH gear motor to the power supply on B1 and B2.</li> <li>5. Close circuit breaker.</li> <li>6. Motor automatically charges the closing spring.</li> <li>7. Remove the power supply.</li> <li>8. Verify the continuity between terminals B1 and B3.</li> </ol> <p><b>ANSI 27 – Undervoltage</b></p> <p>Protection of motors against voltage sags or detection of abnormally low network voltage to trigger automatic load shedding or source transfer. Works with phase-to-phase voltage.</p> <p><b>ANSI 47 – Negative sequence overvoltage</b></p> <p>Protection against phase unbalance resulting from phase inversion, unbalanced supply or distant fault, detected by the measurement of negative sequence voltage.</p>
Indication contacts																																																																			
<b>ON/OFF indication contacts (OF)</b>																																																																			
Changeover contacts (6 A - 240 V)		4 (standard)																																																																	
1 low-level OF to replace 1 standard OF (4 max.)		LV847339																																																																	
<b>"Fault trip" indication contacts (SDE)</b>																																																																			
Changeover contact (6 A - 240 V)		1 (standard)																																																																	
1 additional SDE (6 A - 240 V)		LV847340																																																																	
1 additional low-level SDE		LV847341																																																																	
<b>Programmable contacts (programmed via MicroLogic X control unit)</b>																																																																			
2 contacts (MC) (5 A - 240 V)		LV847403																																																																	
<b>Remote operation</b>																																																																			
<b>"Ready to close" contact (1 max.)</b>																																																																			
1 changeover contact (5 A - 240 V)	RF	LV847342																																																																	
1 low-level changeover contact		LV847343																																																																	
<b>Electrical closing pushbutton</b>																																																																			
1 pushbutton	DPTE	LV847512																																																																	
<b>Remote reset after fault trip</b>																																																																			
Electrical reset	RCS																																																																		
180/130 V AC		LV847344																																																																	
200/240 V AC		LV847345																																																																	
Automatic reset	RAAR																																																																		
Adaptation		LV847346																																																																	
<p><b>Frequency protection functions</b></p> <p><b>ANSI 81H – Overfrequency</b></p> <p>Detection of abnormally high frequency compared to the rated frequency, to monitor power supply quality.</p> <p><b>ANSI 81L – Underfrequency</b></p> <p>Detection of abnormally low frequency compared to the rated frequency, to monitor power supply quality. The protection may be used for overall tripping or load shedding. Protection stability is ensured in the event of the loss of the main source and presence of remanent voltage by a restraint in the event of a continuous decrease of the frequency, which is activated by parameter setting.</p> <p><b>ANSI 81R – Rate of change of frequency</b></p> <p>Protection function used for fast disconnection of a generator or load shedding control. Based on the calculation of the frequency variation, it is insensitive to transient voltage disturbances and therefore more stable than a phase-shift protection function.</p>	<div style="display: flex; justify-content: space-around;"> <div style="text-align: center;">  <p>Phase Sequence Relay, 17.5mm, 600PSR</p> </div> <div style="text-align: center;">  <p>MiCOM P92x Voltage and Frequency Management and Protection Relays</p> </div> </div>																																																																		





electrical diagram n° 889461

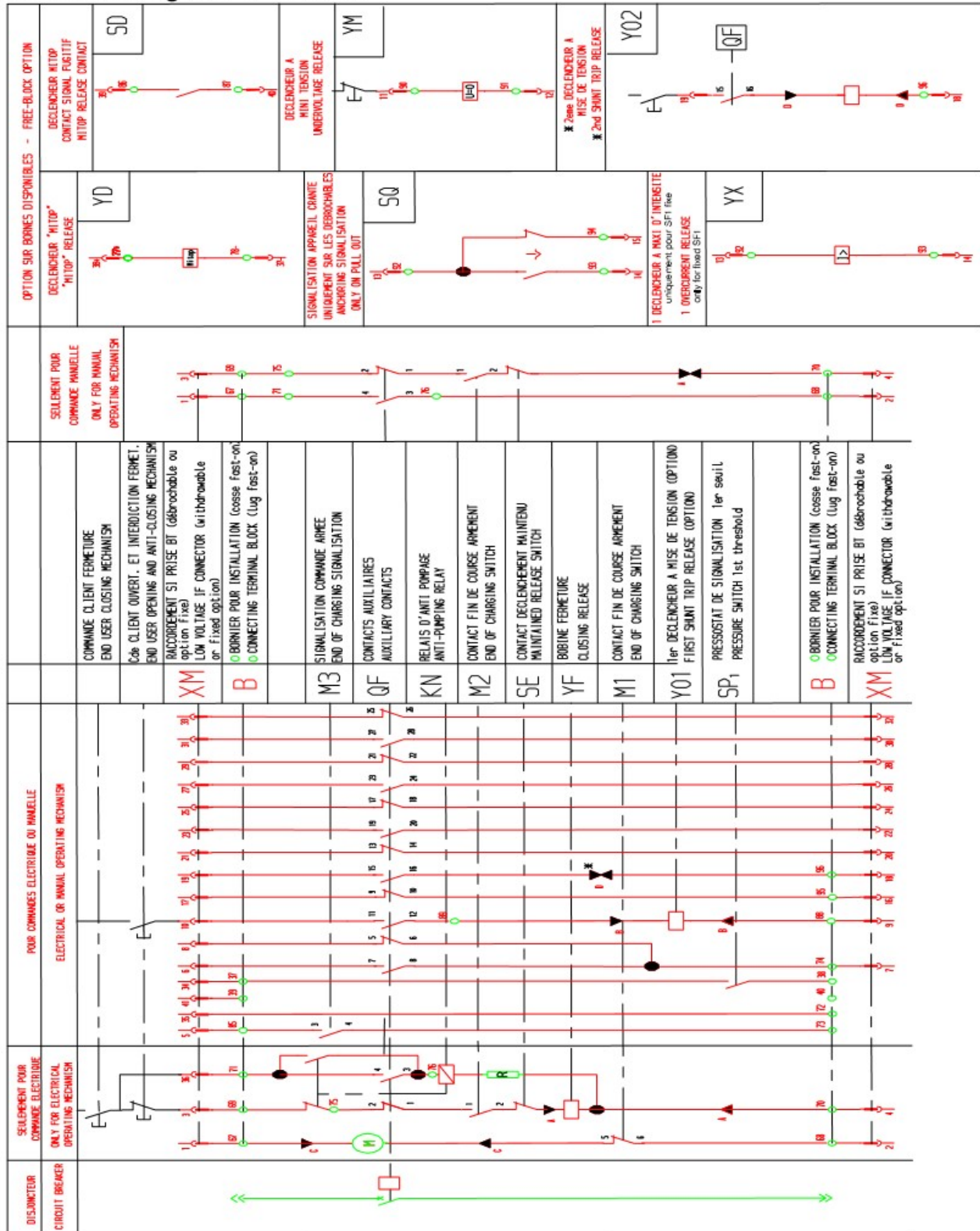



تمرین ۴:

طراحی سیستم کنترل اتوماتیک چراغ راهنمایی توسط PLC

Traffic Light Control using PLC

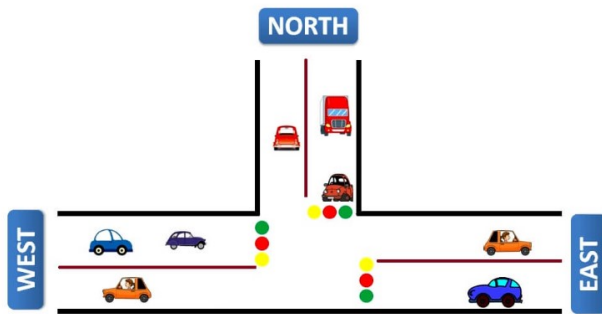

3 - Way Traffic Light Control using PLC

List of Inputs and Outputs for Traffic Control System

S.no	Address	Name	Input/Output
1	I:0/0	Start	Input
2	I:0/1	Stop	Input
3	B3.0	Memory	Memory
4	O:0/0	West Green	Output
5	O:0/1	East Red	Output
6	O:0/2	North Red	Output
7	O:0/3	East yellow	Output
8	O:0/4	East Green	Output
9	O:0/5	West Red	Output
10	O:0/6	North Yellow	Output
11	O:0/7	North Green	Output
12	O:1/0	West Yellow	Output

Below tabular column gives the Steps or sequence of outputs to turn ON.

S.NO	EAST	WEST	NORTH
1	R	G	R
2	Y	G	R
3	G	R	R
4	G	R	Y
5	R	R	G
6	R	Y	G



Title:	کلاس مجازی یوسف علی نژاد برمی_۳۱
Type:	Recording
Duration:	00:49:47
Disk usage:	142856.3 KB
Permissions:	Same as parent folder
URL for Viewing:	<a href="https://vc6.semnan.ac.ir/pij3r8kiqv03/">https://vc6.semnan.ac.ir/pij3r8kiqv03/</a>
Summary:	19-3-99
Recording Date:	06/08/2020 5:34 PM
Title:	کلاس مجازی یوسف علی نژاد برمی_۲۸
Type:	Recording
Duration:	01:19:05
Disk usage:	138303.8 KB
Permissions:	Same as parent folder
URL for Viewing:	<a href="https://vc6.semnan.ac.ir/pw0705lroo9t/">https://vc6.semnan.ac.ir/pw0705lroo9t/</a>
Summary:	130
Recording Date:	06/02/2020 1:32 PM

### تمرین ۵:

دیاگرام زیر در واقع نقشه (P & ID (Piping & Instrumentation Diagram) بخش ذخیره مواد اولیه از یک کارخانه تولیدی را نشان می دهد. در این قسمت به تشریح عملکرد این قسمت می پردازیم و جدول ورودیها و خروجیهای دیجیتالی و آنالوگ را مشخص می کنیم. ابتدا فرایند را به بخشهای زیر تقسیم می کنیم.

#### ۱- بخش انتخاب مخزن ذخیره.

این بخش از چهار مخزن به شماره های ۱۱-۱۲-۱۳-۱۴ تشکیل شده است. و هیچ پیش شرطی برای انتخاب مخزن نداریم. ۱-۱- بر روی هر مخزن یک شاسی انتخاب مخزن از نوع لحظه ای قرار دارد که با یک بار فشردن لحظه ای آن مخزن انتخاب می گردد. (انتخاب به این معنی است که دریچه بالای مخزن انتخاب شده باز می گردد و بقیه دریچه ها بسته می شوند. شرط انتخاب مخزن پر نبودن مخزن است. برنامه کنترلی طراحی شده بایستی این قابلیت را داشته باشد). ۲-۱- بر روی هر مخزن یک سنسور سطح سنج قرار دارد که پر شدن مخزن را اعلام می نماید. ۳-۱- هر دریچه دارای یک شیر برقی است که با اعمال ولتاژ به بوبین آن مسیر باد باز شده و به با مکانیزم پنوماتیکی دریچه باز می گردد و با بی برق شدن شیر برقی و بسته شدن مسیر باد با انرژی ذخیره شده در فنر پشت گیت لغزنده (SlideGate) دریچه بسته می شود.



۱-۴- هر دريچه مجهز به دو سنسور ديگيتالي تحت عنوان سويچ محدود کننده (Limit Switch) مي باشد که با فشرده شدن توسط لبه Slide Gate تحريك مکانیکی گردیده و هر کدام از اين سنسورها با ارسال سيگنال On/Off به ورودی ديگيتال PLC در واقع CPU را از وضعيت باز يا بسته بودن دريچه با خبر مي کنند.

### ۱-۵- آلام ها:

در صورتيکه مخزني که انتخاب مي شود بعد از مثلا ۱۰ ثانيه علامت مربوط به باز بودن دريچه ورودی و همچنين بسته شدن ساير دريچه ها ظاهر نگردد بايستي آلام مشخص صوتی و يا در صورت طراحی بخش مانيتورینگ آلام صوتی و تصويری داده شود.

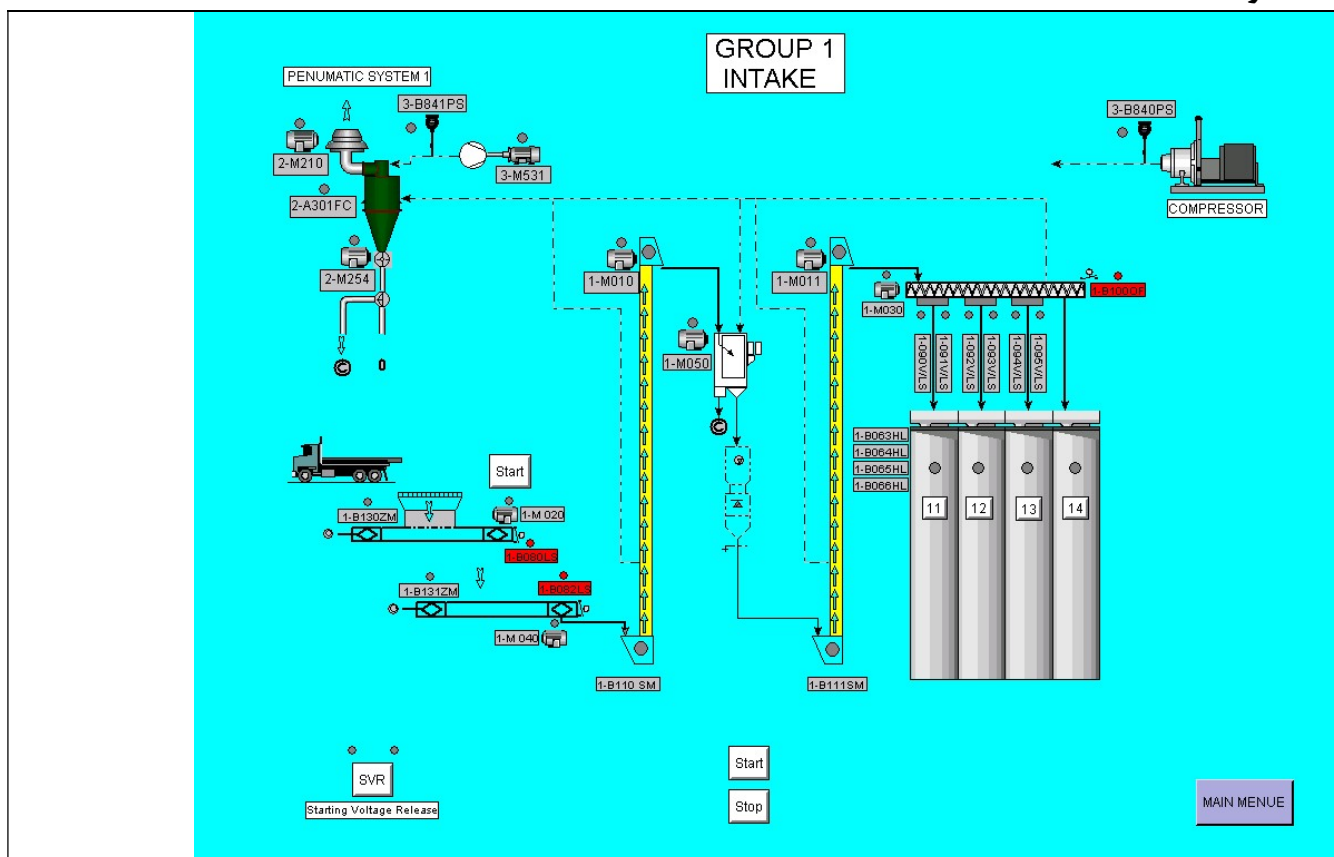

آدرس PLC	تشریح سنسور و کد سنسور	آدرس PLC	تشریح سنسور و کد سنسور	آدرس PLC	تشریح محرک
I 5.0	COMPRESSOR PRESSURE SENSOR	I 6.1	SLIDE GATE NO. 13 OPEN MS	Q 5.0	S. G. V. NO. 11
I 5.1	(1-B063HL) - SILO NO. 11 H.L	I 6.2	SLIDE GATE NO. 13 CLOSE MS	Q 5.1	S. G. V. NO. 12
I 5.2	SILO NO. 12 H.L	I 6.3	SLIDE GATE NO. 14 OPEN MS	Q 5.2	S. G. V. NO. 13
I 5.3	SILO NO. 13 H.L	I 6.4	SLIDE GATE NO. 14 CLOSE MS	Q 5.3	S. G. V. NO. 14
I 5.4	SILO NO. 14 H.L	I 6.5		Q 5.4	SILO FILLING ALARM
I 5.5	SLIDE GATE NO. 11 OPEN MS	I 6.6		Q 5.5	SLIDE GATE ALARM
I 5.6	SLIDE GATE NO. 11 CLOSE MS	I 6.7			
I 5.7	SLIDE GATE NO. 12 OPEN MS	I 7.0			
I 6.0	SLIDE GATE NO. 12 CLOSE MS	I 7.1			

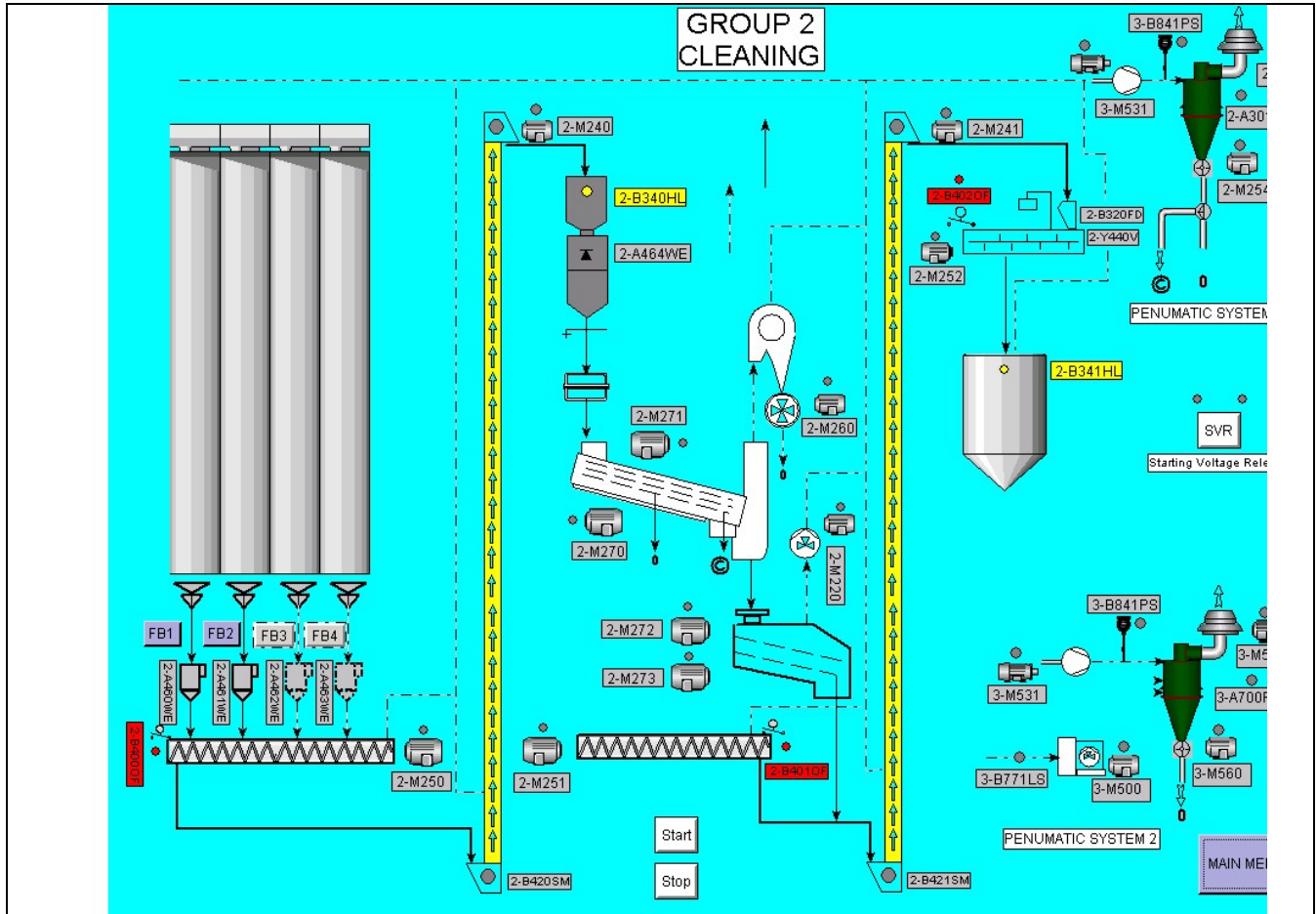

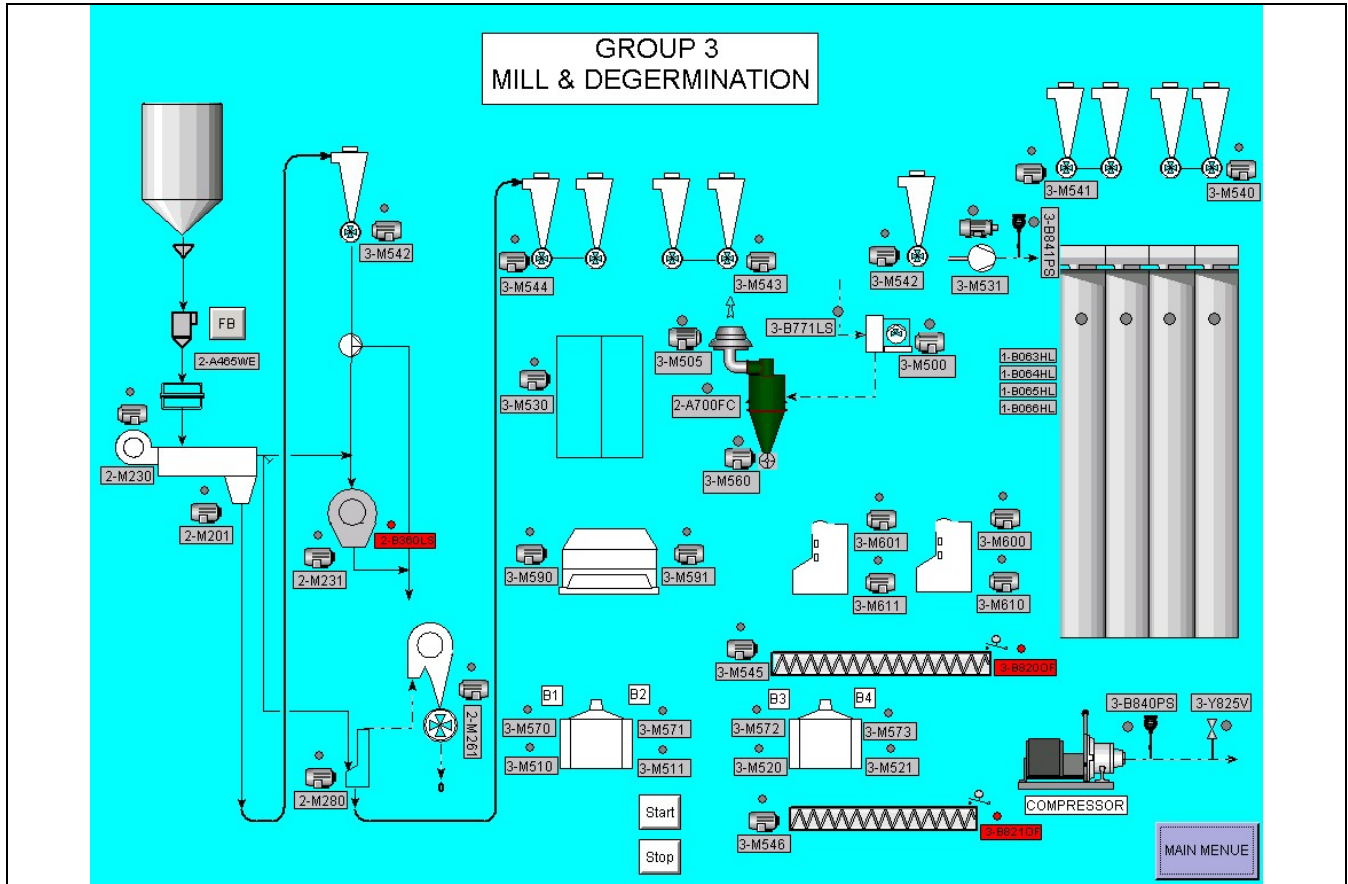

Air Circuit Breaker External Labels



1. OFF button (O)
2. ON button (I)
3. Main contact position indicator
4. Energy storage mechanism status indicator
5. Reset Button
6. LED Indicators
7. Controller
8. "Connection", "Test" and "isolated" position stopper (the three-position latching/locking mechanism)
9. User-supplied padlock
10. Connection "," Test "and" separation "of the position indication
11. Connection (CE) Separation, (CD) Test (CT) Position indication contacts
12. Rated Name Plate
13. Digital Displays
14. Mechanical energy storage handle
15. Shake (IN/OUT)
16. Rocker repository
17. Fault trip reset button



The following fig shows the Internal Construction of Air Circuit Breaker

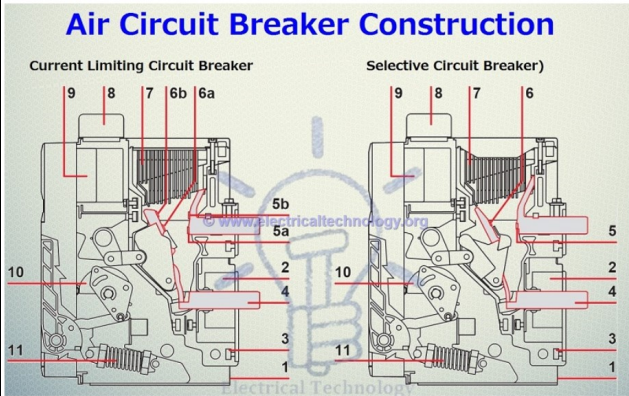

- 1. Sheet Steel Supporting Structure
- 2. Current Transformer for Protection Trip Unit
- 3. Pole Group insulating box
- 4. Horizontal rare terminals
- 5a. Plates for fixed main contacts
- 5b. Plates for fixed arcing Contacts
- 6a. Plates for Main moving contacts
- 6b. Plates for Moving Arcing contacts
- 7. Arcing Chamber
- 8. Terminal box for fixed version – Sliding Contacts for withdrawable version
- 9. Protection Trip Unit
- 10. Circuit breaker Closing and Opening Control
- 11. Closing Springs

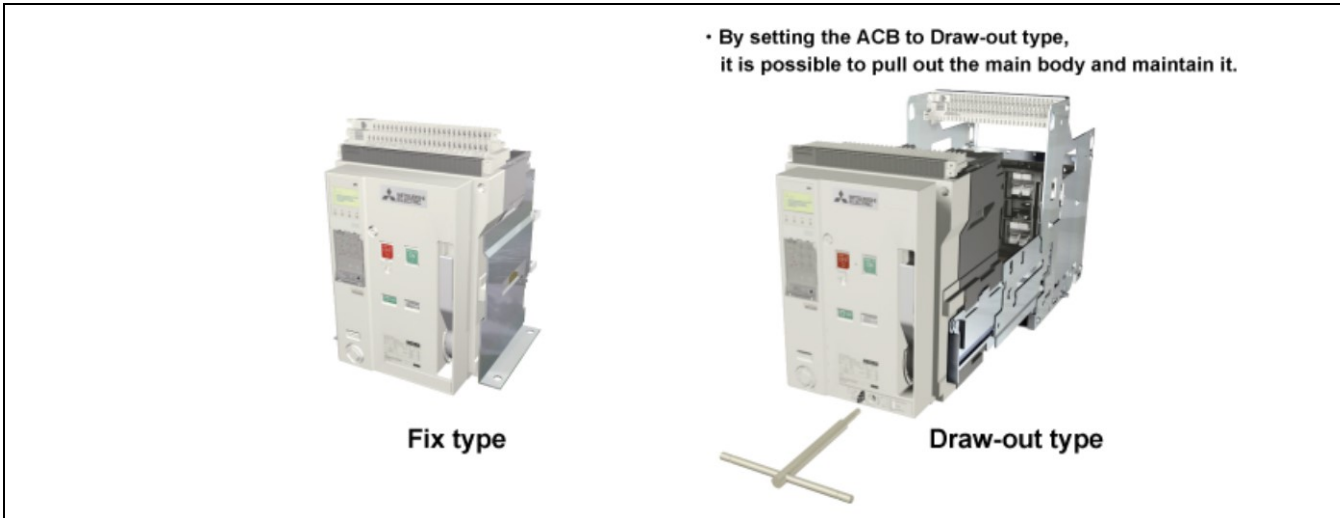

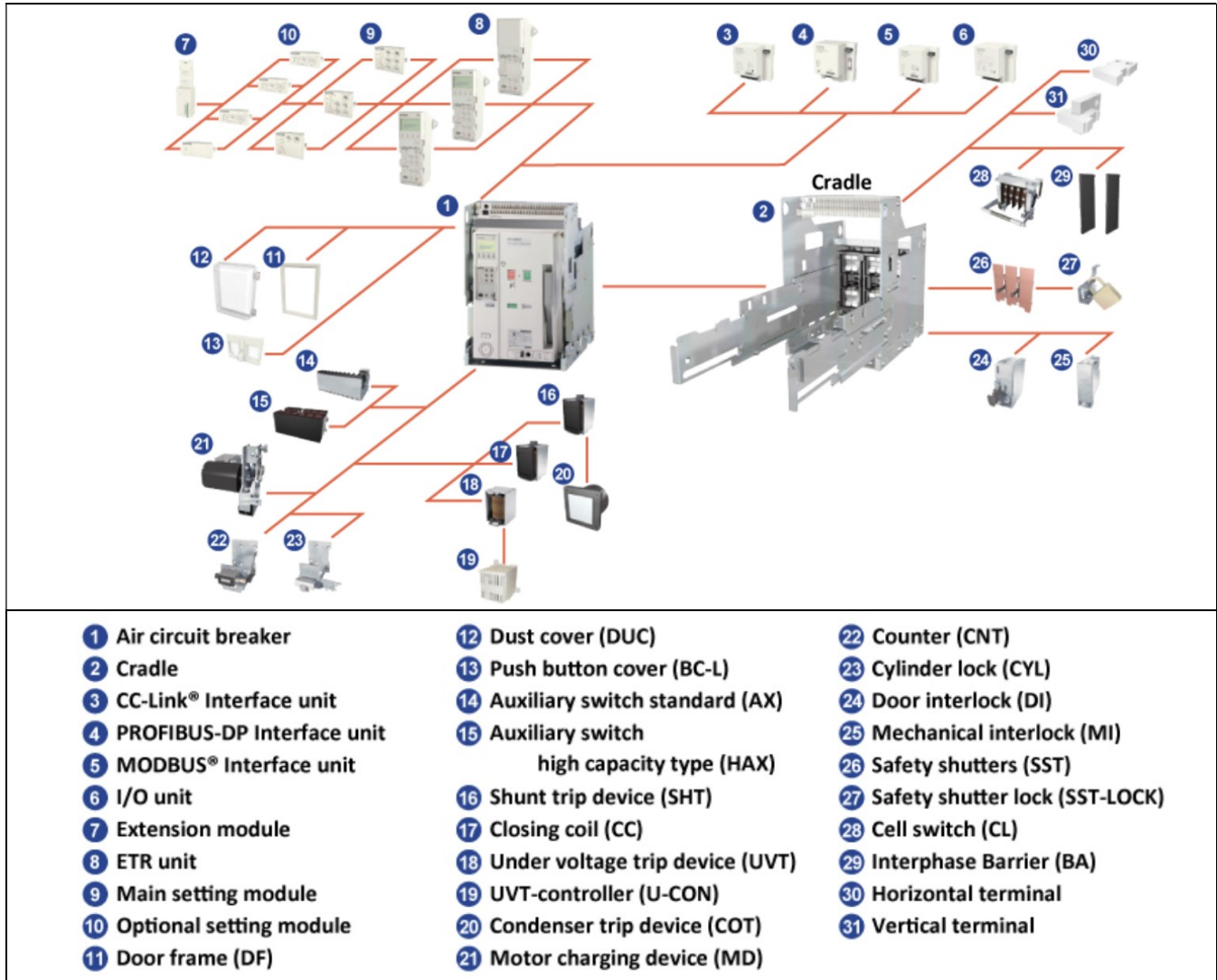





**Basics**

**Analog and digital**

An analog signal is a physical quantity, which, within a given range, can adopt any value - any continuous intermediate value. The opposite of analog is *digital*. A digital signal knows just two states: 0 and 1 or "off" and "on".

**From electrical signal to analog value**

**Basic order of events**

Several steps are required for LOGO! to process physical quantities:

LOGO! can read in electric voltages from 0 V to 10 V or electric currents from 0 mA to 20 mA to one analog input.

The physical quantities (for example, temperature, pressure, speed etc.) must therefore be converted into one electric quantity. This conversion is performed by an external sensor.

LOGO! reads in the electric quantity and, with further processing, converts it into a standardized value within the range 0 to 1000. This value is then used in the circuit program as the input of an analog special function.

In order to adapt the standardized value to the application, LOGO! uses an analog special function, while taking into consideration the gain and offset, to calculate the analog value. The analog value is then evaluated by the special function (for example, analog amplifier). If an analog special function has an analog output, then the value is used as the output of the special function.

With the LOGO! you can also convert analog values back into an electric voltage. In doing so, the voltage can adopt values between 0 V and 10 V.

Using this voltage, LOGO! can control an external actuator, which converts the voltage and also the analog value back into a physical quantity.

The following diagram illustrates this order of events.

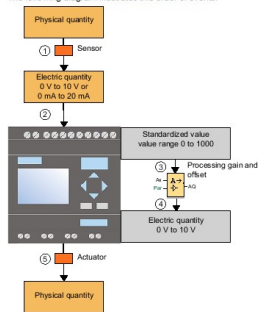

**Gain**

The standardized value is multiplied with a parameter. Using this parameter you can boost the electric quantity; hence, this parameter is called the "gain".

**Zero point offset**

You can add or subtract a parameter to or from the boosted standardized value.

Using this parameter you can move the zero point of the electric quantity; hence, this parameter is called the "zero point offset".

**Gain and offset**

The analog value is therefore calculated as follows:

**Analog value** = (standardized value x gain) + offset

The following diagram illustrates this formula and the significance of gain and offset.

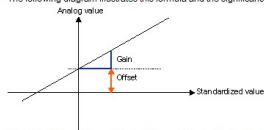

The straight line in the graphic describes which standardized value is being converted into which analog value. Gain corresponds to the slope of the straight line and offset to the movement of the zero point of the straight line on the y-axis.

**Analog output**

If you connect a special function (that has an analog output) to a real analog output, then note that the analog output can only process values from 0 to 1000.

**Possible settings with LOGO!Soft Comfort**

**Sensor**

Set your sensor type. (0 V to 10 V; 0 mA to 20 mA; 4 mA to 20 mA; PT100/PT1000; no sensor)

With sensor type 4 mA to 20 mA the value range for the standardized value is 200 and 1000.

**Measurement range**

Stipulate the measurement range. The measurement range is the value range shown for the analog value.

The screenshot shows the 'Sensor' dropdown set to '0 ... 10 V'. Under 'Analog Setting', the 'Measurement Range' is set with Minimum: 0 and Maximum: 1000. The 'Parameter' section shows Gain: 1.00 and Offset: 0.

LOGO!Soft Comfort then automatically calculates the gain and offset from this.

**Gain and offset**

If you want to set the gain, you can enter values between -10.00 and 10.00. The value 0 makes no sense, as, irrespective of the applied analog value, you will always obtain the value 0 as a result.

If you wish to set the offset, enter values between -10000 and 10000.

**Rounding error**

LOGO!Soft Comfort calculates the gain and zero point offset with utmost precision, while LOGO! calculates internally using whole numerical values; therefore, not all parameter combinations are possible on LOGO!. In this case, a value range.

**Simulation in LOGO!Soft Comfort**

With simulation in LOGO!Soft Comfort you can read the following values:

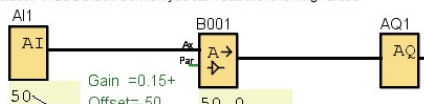



**Example**

**Prerequisites**

Sensor: temperature sensor, measuring range: -50 °C to 100 °C  
 Temperature to be measured: 25 °C

**Order of events with LOGO!Soft Comfort**

The sensor converts the temperature from 25 °C to a voltage value of 5.0 V.  
 LOGO!Soft Comfort converts the 5.0 V to the standardized value 500.  
 Using the sensor and measurement range data, LOGO!Soft Comfort calculates and ascertains the value 0.15 for the gain and the value -50 for the offset.  
 According to the formula:  
 Analog value = (standardized value × gain) + offset  
 LOGO!Soft Comfort calculates as analog value:  
 Analog value = (500 × 0.15) - 50 = 25

**Order of events with LOGO!**

The sensor converts the temperature from 25 °C to a voltage value of 5.0 V.  
 LOGO! converts the 5.0 V to the standardized value 500.  
 From the sensor and measuring range data, you must establish the values for gain and offset.  
 According to the formulas:  
 $Gain = (max_{Sensor} - min_{Sensor}) / (max_{norm} - min_{norm})$   
 and  
 $Offset = min_{Sensor} - (Gain \times min_{norm})$   
 it follows that  
 $Gain = (100 - (-50)) / (1000 - 0) = 0.15$   
 $Offset = -50 - (0.15 \times 0) = -50$   
 According to the formula  
 Analog value = (standardized value × gain) + offset  
 LOGO! calculates as analog value:  
 Analog value = (500 × 0.15) - 50 = 25

**Additional examples**

Physical quantity	Electric quantity of sensor	Standardized value	Gain	Offset	Analog value
	0 V 5 V 10 V	0 500 1000	0.01	0	0 5 10
	4 mA 12 mA 20 mA	0 500 1000	10	0	0 5000 10000
	0 mA 10 mA 20 mA	0 500 1000	1	50	50 550 1050
1000 mbar 3700 mbar 5000 mbar	0 V 6.75 V 10 V	0 675 1000	4	1000	1000 3700 5000
-30 °C 0 °C 70 °C	0 mA 6 mA 20 mA	0 300 1000	0.1	-30	-30 0 70

**OBA0 to OBA4**



**Restriction for device family OBA4**

The Gain cannot be a negative value.

**Calculation with the device families OBA0 to OBA3**

With LOGO! devices from these device families, LOGO! adds or subtracts the parameter offset to or from the standardized value **before** multiplying the value with the parameter gain.  
 Therefore, the following formulas apply:

**Analog value** = (standardized value + offset) × (gain × 100)  
 $Gain \text{ (in percent)} = (max_{Sensor} - min_{Sensor}) / [(max_{norm} - min_{norm}) \times 100]$   
 $Offset = [(min_{Sensor} \times max_{norm}) - (max_{Sensor} \times min_{norm})] / (max_{Sensor} - min_{Sensor})$   
 $Gain \text{ (in percent)} = min_{Sensor} / [(min_{norm} + offset) \times 100]$   
 $Offset = [max_{Sensor} / (gain \times 100)] - max_{norm}$

**Gain**

This parameter is given in %.  
 The [Gain](#) cannot be a negative value.

**Zero point offset**

You can enter values between -999 and +999 for the [zero point offset](#).



STEP 7-Micro/WIN - SABA-2-Project1-22-5-98

File Edit View PLC Debug Tools Windows Help

View

- Program Block
- Symbol Table
- Status Chart
- Data Block
- System Block
- Cross Reference
- Communications
- Set PG/PC Interface

SABA-2-Project1-22-5-98 (C:\User\...)

- What's New
- CPU 224 REL 02.01
- Program Block
- Symbol Table
- Status Chart
- Data Block
- System Block
- Cross Reference
- Communications
- Wizards
- Tools
- Instructions
  - Favorites
  - Bit Logic
  - Clock
  - Communications
  - Compare
  - Convert
  - Counters
  - Floating-Point Math
  - Integer Math
  - Interrupt
  - Logical Operations
  - Move
  - Program Control
  - Shift/Rotate
  - String
  - Table
  - Timers
  - Libraries
  - Call Subroutines

SIMATIC LAD

Network 17

```

    VD308 M15.1
    <R-----)
    VD22
    
```

Network 18

```

    M10.0 M31.2 M15.0 M15.1 M15.2
    -----)
    
```

Network 19

```

    SM0.0
    |
    +--- LDI ENO
        |
        | AIW4 IN OUT VD8
        |
    +--- DI_R ENO
        |
        | VD8 IN OUT VD8
        |
    +--- DIV_R ENO
        |
        | VD8 IN1 OUT VD8
        |
        | 10.0 IN2
        |
    -----)
    
```

<p><b>Point Level Measurement</b></p>	<p><b>Continuous Level Measurement</b></p>	<p><b>Current - Mode Analog Inputs</b></p>
<p><b>Profibus-DP</b></p> <p>↓</p> <p>Process Field Bus</p> <p>↓</p> <p>Decentralized Peripherals</p>		<p><b>Continuous Ultrasonic Level Sensor</b></p>



<p><b>Continuous</b> <b>Ultrasonic Level Sensor</b></p>	<p><b>Level Sensor</b></p> <p>Point Level Measurement      Continuous Level Measurement</p>						
<p><b>Point</b> <b>Float Switch Level Sensor</b></p>	<p><b>Continuous</b> <b>Ultrasonic Level Sensor</b></p> <table border="1"> <thead> <tr> <th>Advantage</th> <th>Disadvantage</th> </tr> </thead> <tbody> <tr> <td>Non-Invasive</td> <td>Expensive</td> </tr> <tr> <td>Self-Cleaning</td> <td>Negative Effect of Environment</td> </tr> </tbody> </table>	Advantage	Disadvantage	Non-Invasive	Expensive	Self-Cleaning	Negative Effect of Environment
Advantage	Disadvantage						
Non-Invasive	Expensive						
Self-Cleaning	Negative Effect of Environment						
<p><b>Level Sensor</b></p> <p>Point Level Measurement</p>	<p><b>Point Level Measurement</b>      <b>Continuous Level Measurement</b></p>						
<p><b>Level Sensor</b></p>	<p><b>Level Sensor</b></p>						
	<p>Scaled output values</p> <p>Analog input values (bipolar)</p> <p><math>I_{sl} = -32000</math>      <math>I_v</math>      <math>I_{sh} = 32000</math></p> <p><math>O_{sh}</math>      <math>O_v</math>      <math>O_{sl}</math></p>						



--	--